



Model CF-980

**Centurion™
Water Filtration Vacuum**



by Top Innovations, Inc.

**Please read instructions before use.
Mail in your warranty registration card.**



LETTER FROM THE CEO

Dear Valued Customer,

Thank you for purchasing the **Centurion™** water filtration vacuum. Discover a new way to vacuum with this versatile and convenient new product, which uses a unique triple filtration system to trap dirt and dust, all without the need for replacing messy and inconvenient vacuum bags.

Fill your **Centurion™** with water and plug it in, and you are ready to eliminate dirt and dust from the floors of your home, both carpeted and hard surface. Using a remarkable filtration system that combines water, a sponge filter, and a powerful ULTRA filter, the **Centurion™** minimizes the amount of escaping dust particles being thrown back into the air. Not only will your floors be cleaner than ever, but so will the very air that you and your family breathe.

Top Innovations, Inc. would like to invite you to take advantage of our Customer Support web site at:

www.topinnovations.com

On this website you will find additional information about many other exciting CleanFast™ products that are available, as well as a number of helpful tips on ways in which you can fully utilize your **Centurion™**!

Enjoy your new **Centurion™**!

A handwritten signature in cursive script, appearing to read "Benny Lee".

Benny Lee
Chairman and CEO
Top Innovations, Inc.



IMPORTANT SAFEGUARDS



WARNING: To reduce the risk of fire, electrical shock, or injury, the following basic safety precautions should always be followed when using an electrical appliance.

READ ALL INSTRUCTIONS BEFORE USING YOUR VACUUM

- 1) DO NOT leave your CF-980 Centurion™ unattended when plugged in or not in use.
- 2)  **This unit is not a toy. Close supervision is required when using unit near children, pets, and plants.**
- 3) Always unplug electrical cord when unit is not in use. DO NOT use this unit if electrical cord or outlet is damaged. DO NOT use unit if it is not working properly or has been dropped, damaged, or left outdoors. If such damage occurs, contact an approved service technician for assistance.
- 4) This unit is an electrical appliance. DO NOT submerge it in water. DO NOT use electrical cord or hose as a handle. DO NOT allow cord or hose to be crimped by closing it in doors. DO NOT pull or stretch cord or hose around sharp corners or edges. Be sure to keep electrical cord away from all heated surfaces.
- 5) DO NOT use this unit with extension cords or electrical outlets that have inadequate current capacity. A three-prong outlet or a properly grounded adapter is necessary when using CF-980 Centurion™.
- 6) In order to unplug CF-980 Centurion™, grasp plug and pull smoothly and firmly from outlet. DO NOT attempt to unplug unit by pulling or tugging on cord.
- 7) DO NOT handle or use this unit while hands are wet or when not wearing shoes.

SAVE THESE INSTRUCTIONS!

FOR HOUSEHOLD USE ONLY



IMPORTANT SAFEGUARDS



WARNING: To reduce the risk of electric shock, this appliance has a three-pronged plug. This plug will fit in a polarized wall outlet only one way. If the plug does not fit fully in the outlet, contact a qualified electrician to install a proper outlet. **DO NOT** attempt to modify the plug or defeat this safety feature in any way.

- 8)** CF-980 Centurion™ is only meant to be used with recommended CF-980 accessories. Other types of attachments such as those used with other vacuum cleaners are not to be used with Centurion™. Doing so may cause injuries or damage to unit.
- 9)** **DO NOT** use Centurion™ to vacuum liquids. **DO NOT** vacuum matches, ashes, or cigarette butts that are still lit.
- 10)** **DO NOT** turn unit on its side when in use.
- 11)** When filling your Centurion™ with water, **DO NOT** overfill Water Reservoir. Doing so may cause damage to main unit motor.
- 12)** Before filling or emptying Water Reservoir, always take the following steps:
- 1) Turn appliance off
 - 2) Unplug electrical cord
- Failure to follow these steps may result in electric shock and injury.
- 13)** Only water should be used in unit. Other cleaning agents will damage unit and can cause injuries.
- 14)** Keep hair, loose clothing, fingers, and all parts of the body away from openings and moving parts.
- 15)** Store your CF-980 Centurion™ in a cool, dry place. Always drain and clean Water Reservoir before storing.

SAVE THESE INSTRUCTIONS!

FOR HOUSEHOLD USE ONLY



CF-980 CENTURION™ PRODUCT INFORMATION

The following features and accessories come with your steam cleaner. Carefully inspect packaging material as some parts are shipped inside Styrofoam packaging. To obtain possible missing parts, refer to the **Customer Support** section on page 13 of this manual.

MAIN UNIT

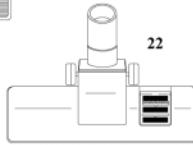
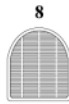
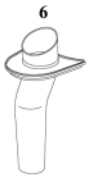
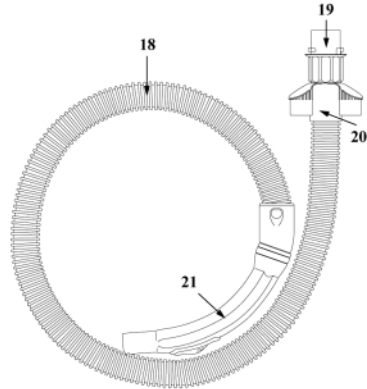
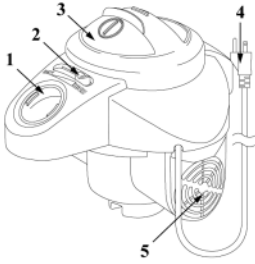

REMOVABLE WATER TANK

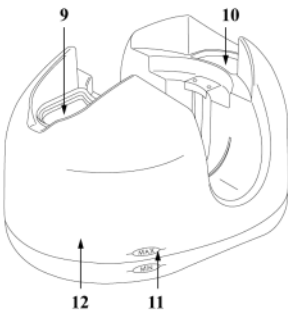

CRADLE CAR

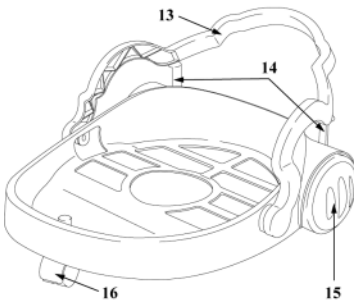

UNIT FEATURES AND ACCESSORIES

- 1) Inlet Nozzle Hole
- 2) Suction Power Control
- 3) On/Off Switch
- 4) Grounded Power Cord
- 5) Side Vent Panel
- 6) Removable Suction Tube
- 7) Sponge Filter
- 8) ULTRA Filter
- 9) Suction Tube Inlet
- 10) Sponge Filter Inlet
- 11) Maximum Fill Line
- 12) Water Reservoir
- 13) Locking Handle
- 14) Power Cord Holders
- 15) Large Wheels
- 16) Front Caster
- 17) Telescopic Extension Tube
- 18) Flexible Hose
- 19) Inlet Nozzle
- 20) Accessory Holder
- 21) Main Siphon
- 22) Floor Brush
- 23) Crevice Tool
- 24) Upholstery Tool



CF-980 CENTURION™ PRODUCT INFORMATION

- The *Inlet Nozzle Hole* (1) is where the *Inlet Nozzle* of the *Flexible Hose* connects to the main unit.
- The *Suction Power Control* (2) lets you adjust how powerful the vacuum suction is.
- The *On/Off Switch* (3) activates and deactivates the unit.
- The *Grounded Power Cord* (4) provides exceptional mobility while protecting against electric shock and injury.
- The *Side Vent Panel* (5) is where exhaust is emitted from the unit. The left *Side Vent Panel* (not shown) is removable and houses the ULTRA filter.
- The *Removable Suction Tube* (6) is inserted into the removable water tank and funnels vacuumed materials into the water in the *Water Reservoir*.
- The *Sponge Filter* (7) is inserted into the removable water tank and provides extra filtration. It uses a built-in safety float to control the amount of water and materials that is drawn through the filter.
- The *ULTRA Filter* (8) fits inside the left *Side Vent Panel*, and helps to prevent dust and other impurities from being released back into the air.
- The *Suction Tube Inlet* (9) is where the *Suction Tube* is inserted into the removable water tank. Water is also poured into the *Water Reservoir* through this hole.
- The *Sponge Filter Inlet* (10) is where the *Sponge Filter* is inserted into the removable water tank.
- The *Maximum Fill Line* (11) indicates the maximum amount of water that can safely be poured into the *Water Reservoir*, and should never be exceeded.
- The *Water Reservoir* (12) is where water is poured to assist in the filtration process.
- The *Lifting Handle* (not shown) located in the middle-bottom of the main water tank allows you to more easily lift the main water tank into and out of the cradle car.
- The *Locking Handle* (13) flips up to securely attach the removable water tank and the main unit to the cradle car.
- The *Power Cord Holders* (14) are the pegs that the *Grounded Power Cord* is looped around for safe and convenient storage.
- The *Large Wheels* (15) and *Front Caster* (16) work in conjunction to provide exceptional freedom and maneuverability.
- The *Telescopic Extension Tube* (17) is attached to the *Main Siphon* and greatly increases your reach, allowing you to more easily vacuum floors and hard to reach surfaces.
- The *Flexible Hose* (18) connects the *Main Siphon* to the main unit, and allows you the flexibility for any vacuuming needs. It connects to the main unit via the *Inlet Nozzle* (19), and is equipped with an *Accessory Holder* (20), which can be slid to any point along the *Flexible Hose* and conveniently stores the *Crevice Tool* and *Upholstery Tool*. The *Main Siphon* (21) serves as the handle while vacuuming, and the nozzle to which the *Telescopic Extension Tube* is attached.
- The *Floor Brush* (22) attaches to the end of the *Telescopic Extension Tube* and can be used to clean both carpeted and hardwood floors.
- The *Crevice Tool* (23) may be attached to the *Telescopic Extension Tube* in place of the *Floor Brush*, and is designed for cleaning in narrow, hard-to-reach places.
- The *Upholstery Tool* (24) may be attached to the *Telescopic Extension Tube* in place of the *Floor Brush*, and is designed to safely and effectively clean furniture, curtains, and other upholstered surfaces.

ASSEMBLING MAIN UNIT

- 1) Insert removable water tank onto cradle car (FIGURE 1). A raised cylinder in bottom of tank (directly under the Suction Tube Inlet) will line up with peg at front of cradle car.
- 2) Insert Removable Suction Tube into Suction Tube Inlet as shown (FIGURE 2-A). Align it with the shape of the hole, and press down to make sure it is set securely in place.
- 3) Insert Sponge Filter into Sponge Filter Inlet as shown (FIGURE 2-B). Align it with the shape of the hole, and press down to make sure it is set securely in place.
- 4) Insert main unit into removable water tank as shown (FIGURE 3). It will not snap into place, but will be held securely when Locking Handle is flipped up into place as shown (FIGURE 4). Main unit, removable water tank, and cradle car will be held securely together when Locking Handle snaps into place.

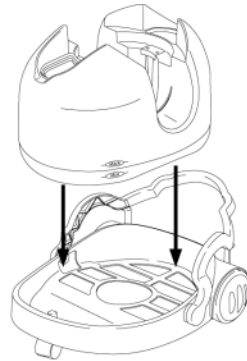
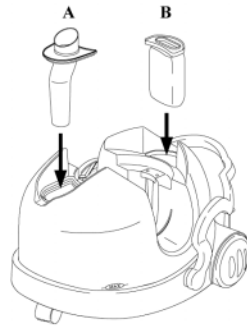
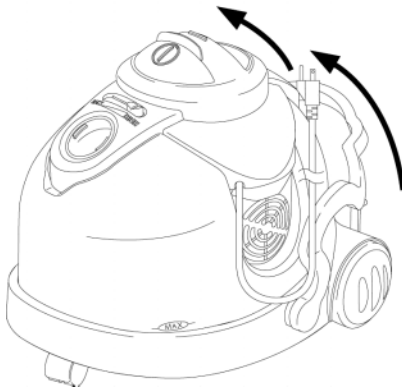
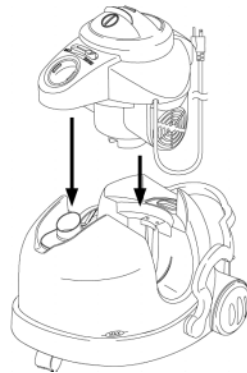
**FIGURE 1****FIGURE 2****FIGURE 4****FIGURE 3**

ATTACHING HOSE AND ACCESSORIES

1) Insert Inlet Nozzle of Flexible Hose into Inlet Nozzle Hole on main unit as shown (FIGURE 5). Insert it so that guides on sides of Inlet Nozzle (FIGURE 5-A) fit between tabs inside Inlet Nozzle Hole (FIGURE 5-B). Turn Inlet Nozzle clockwise until snug.

2) Slide Telescopic Extension Tube onto end of Main Siphon as shown (FIGURE 6). Firmly press Tube onto Siphon until it is snug and secure.

3) Attach Floor Brush (FIGURE 7-A), Crevice Tool (FIGURE 7-B), or Upholstery Tool (FIGURE 7-C) onto end of Telescopic Extension Tube as shown (FIGURE 7). Firmly press attachment onto Tube until it is snug and secure.

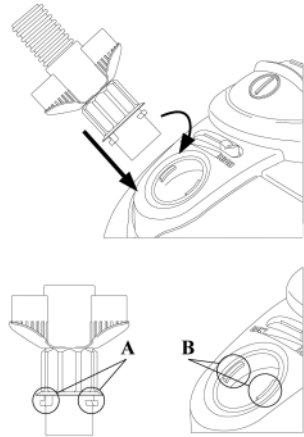

FIGURE 5

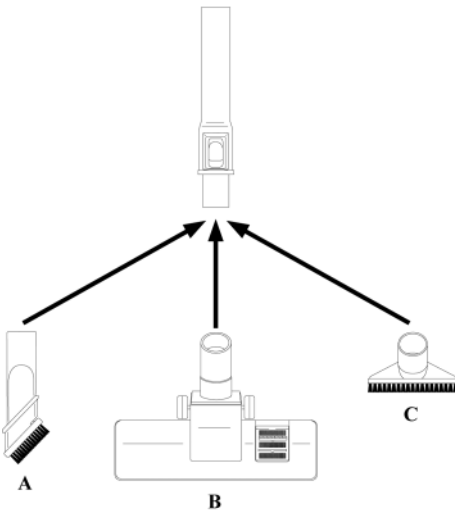

FIGURE 7

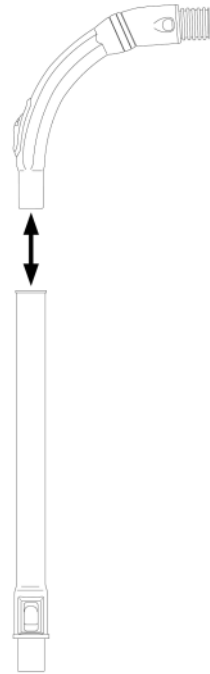

FIGURE 6



USING THE CENTURION™

FILLING WATER RESERVOIR

- 1) Release Locking Handle and pull it back to rest on top of Power Cord Holders.
- 2) Carefully remove main unit from removable water tank and set it aside.
- 3) Using Lift Handle in bottom of removable water tank, lift water tank out of cradle car, and carry it to a convenient sink or tub.
- 4) Remove Suction Tube from Suction Tube Inlet, fully exposing inlet hole. Note that this step is not necessary, but may make it easier to pour water into Water Reservoir.
- 5) Begin pouring water through inlet hole into Water Reservoir. Ordinary tap water of mild temperature is ideal.

IMPORTANT: When pouring water into Water Reservoir, DO NOT exceed Maximum Fill Line mark on side of removable water tank. Doing so may cause damage to main unit motor.

- 6) Replace Removable Suction Tube into Suction Tube Inlet (if you chose to remove it in Step 4).
- 7) Once again using Lift Handle, carefully place filled water tank back onto cradle car.
- 8) Replace main unit back into removable water tank, and return Locking Handle to its upright position to secure the unit together.



USING THE CENTURION™

VACUUMING

- 1) Make sure main unit, removable water tank, and cradle car are fully assembled (see directions on pages 7 and 8 of this manual for assistance), and ensure that Locking Handle is securely in place.
 - 2) Connect hose to main unit. Connect Telescopic Extension Tube to Main Siphon. Connect desired attachment (Floor Brush, Upholstery Tool, Crevice Tool) to Telescopic Extension Tube.
 - 3) Plug Grounded Power Cord into a convenient three-prong electrical outlet.
 - 4) Press On/Off Switch once to activate unit. You are now free to begin vacuuming.
 - 5) Suction power of vacuum can be controlled by setting Suction Power Control switch to either high or low setting. High setting is recommended as default setting, but you may find low setting is more effective in certain situations (such as vacuuming especially delicate drapes and upholstery).
- NOTE: Suction power may also be adjusted using control switch on Main Siphon. See “Main Siphon” section on page 11 of this manual for more details.**
- 6) Once vacuuming task is completed, press On/Off Switch once to deactivate unit. Immediately unplug Grounded Power Cord from electrical outlet.
 - 7) Refer to **Proper Storage** section on page 12 of this manual for information on appropriate steps for cleaning and storage of Centurion™.

MAIN SIPHON

Suction power may be controlled using secondary control switch on top of Main Siphon (FIGURE 8). Reducing suction power allows you to safely change attachments, and allows safe usage on delicate fabrics and upholstery.

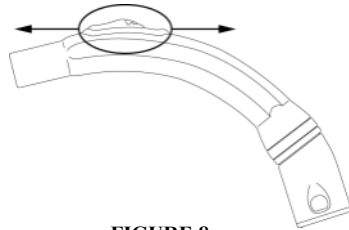

FIGURE 8

TELESCOPIC EXTENSION TUBE

Telescopic Extension Tube length may be adjusted using switch at end of tube (FIGURE 9). Simply depress switch and pull extension end of tube outwards. Once you have reached desired length, release switch and shift extension end slightly until it “clicks”. This will cue you that it is securely locked in place.



FIGURE 9

FLOOR BRUSH

Floor Brush may be effectively used on both carpeted and hardwood floors by pressing brush height adjustment switch into either “lowered” or “raised” positions.

For vacuuming carpeted floors, set brush height adjustment switch to “lowered” position (FIGURE 10-A). For vacuuming hardwood floors, set brush height adjustment switch to “raised” position (FIGURE 10-B).

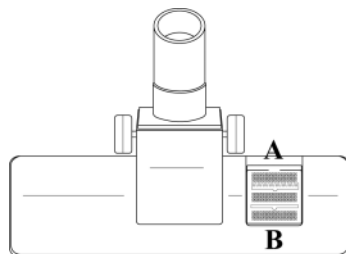

FIGURE 10

CLEANING / REPLACING ULTRA FILTER

- 1) Remove main unit from removable water tank.
- 2) Holding main unit upside-down in your lap, press in and outwards on locking tab (note only left Side Vent Panel has this tab and is removable). While still pressing on tab, pull Side Vent Panel outwards to disconnect it (FIGURE 11).
- 3) Gently press in on bottom of ULTRA filter to push the top outwards. Grasp top of filter and pull it outwards to remove it from its housing (FIGURE 12).
- 4) Gently and thoroughly rinse ULTRA filter under lukewarm running tap water.

IMPORTANT: Allow ULTRA filter to COMPLETELY DRY before reinserting it back into main unit housing.

- 5) Once ULTRA filter is reinserted, reattach Side Vent Panel by first inserting locking tab, then swinging other end of vent into housing. Side Vent Panel should “click” securely into place.

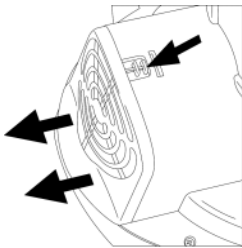

FIGURE 11

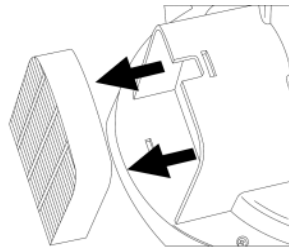

FIGURE 12

In order to maximize the effectiveness of your Centurion’s™ filtration system, it is recommended that you replace the ULTRA filter every 2-4 months (depending on frequency of use). For more information on ordering replacement ULTRA filters, please refer to the Accessory Ordering Guide on page 14 of this manual.

PROPER STORAGE

Preparing your Centurion™ for storage is quick and simple. When you have finished your vacuuming tasks, follow the steps listed below:

- 1) Unplug Grounded Power Cord from electrical outlet.
- 2) Remove all attachments and accessories from unit.
- 3) Remove main unit from removable water tank.
- 4) Remove water tank from cradle car. Drain any remaining water in Water Reservoir into a sink or tub. Flush out Water Reservoir with fresh water to remove any remaining dirt or materials from Water Reservoir.
- 5) Remove Sponge Filter from removable water tank and thoroughly rinse it under running water. Place it back into Sponge Filter Inlet once it is COMPLETELY DRY (keeping Sponge Filter dry will help prolong its lifetime).
- 6) Reassemble unit, and place Crevice Tool and Upholstery tool onto Accessory Holder by sliding each one onto one of the holders two cylinders.
- 7) Loop Grounded Power Cord loosely around Power Cord Holders.
- 8) Store Centurion™ in a cool, dry location.



TROUBLESHOOTING GUIDE

PROBLEM	POSSIBLE CAUSE	SOLUTION
Unit fails to turn on.	Vacuum is not plugged in.	Plug into electrical outlet.
	Household Circuit Breaker / Ground Fault Interrupter has tripped or blown a fuse.	Reset Circuit Breaker / Ground Fault Interrupter, or replace fuse. If you need assistance, contact a qualified electrician.
Unit turns on, but suction is very weak or there is no suction at all.	Hose, Removable Suction Tube, or one of the accessories has become clogged.	Carefully inspect for any blockages and remove any you find.
	Suction Power Control on main unit or Main Siphon is set to "low".	Check that both Suction Power Controls are set to "high".
	ULTRA filter is no longer functioning efficiently.	Remove and clean ULTRA filter, or replace it with a new one.
There is water leakage during wet vacuuming.	Float blocked and/or no float filter.	Release float, clean and/or dry foam filter.

CUSTOMER SUPPORT

For problems with your steam cleaner, refer to the Troubleshooting Guide located above. Additional inquiries should be directed to our Customer Support services at 1-800-711-6617 ext. 102 / 130 or e-mailed to:

customerservice@topinnovations.com

Should there be any missing or defective parts or accessories, contact Customer Support. In most cases, it is not necessary to return the entire unit. We can ship most parts directly to your door.

To ensure prompt and accurate service, call for a Return Authorization number before returning any unit to Top Innovations. Failure to obtain a Return Authorization number will cause a delay in warranty or out-of-warranty service requests.

ACCESSORY ORDER FORM

PART	PART DESCRIPTION	PRICE	QTY.	TOTAL
A980-001	Floor Brush	\$12.99		
A980-002	Sponge Filter	\$2.99		
A980-003	Telescopic Extension Tube	\$12.99		
A980-004	Hose	\$12.99		
A980-005	Crevice Tool	\$5.99		
A980-006	Upholstery Tool	\$5.99		
A980-007	Main Siphon	\$5.99		
A980-008	ULTRA Filter	\$5.99		
Subtotal				
+ S&H				\$3.99
Total USD				

ORDER ONLINE TODAY
 To try our convenient and totally secure online ordering service, visit us at www.topinnovations.com.

Method of Payment (no C.O.D. orders)

Check or Money Order (payable to Top Innovations)

Charge to my VISA MASTERCARD

--	--	--	--	--	--	--	--	--	--	--	--	--	--	--	--	--	--

ACCOUNT NUMBER

--	--	--	--

EXPIRATION DATE

SIGNATURE: _____
 (Full name as shown on account)

NAME: _____

MAILING ADDRESS: _____

TELEPHONE: _____

TO ORDER:
ONLINE
 Visit our website at www.topinnovations.com

BY MAIL
 Fill out this form and return to address on back of this manual

BY PHONE
 (800) 711-6617
 EXT. # 102/130

BY FAX
 (816) 584-9066



WARRANTY INFORMATION

ONE YEAR LIMITED WARRANTY

(If outside USA, additional shipping charges may apply)

Top Innovations, Inc. warrants this product to be free from defects in material and workmanship for a period of one (1) year from the date of purchase. This warranty does not cover damage caused by misuse, negligence, use by improper current or voltage, use contrary to operating instructions or disassembly, repair or alteration by any person other than Top Innovations, Inc. Warranty Service Department.

Top Innovations, Inc. will repair or replace, at its option. This warranty gives you specific legal rights and may have other rights, which may vary from state to state.

Performance of any obligation under this warranty may be obtained by:

1. Call (800) 711-6617 for Return Authorization Number before returning for repair
2. Include copy of purchase receipt
3. Include your name, address, telephone number, and Return Authorization Number on returned package

Please send product postage prepaid to:

TOP INNOVATIONS, INC.
WARRANTY SERVICE DEPARTMENT
400 NW PLATTE VALLEY DR.
RIVERSIDE, MO 64150

After 1 year limited warranty has expired, you will be advised of the cost of repair before any servicing is done unless you enclose a note indicating that you would like us to proceed with repairs.

If you have any questions about coverage under this warranty, you may contact warranty service department by telephone at (800) 711-6617 ext. 102 / 130 or e-mail customerservice@topinnovations.com



Top Innovations, Inc.

400 NW Platte Valley Dr.

Riverside, MO 64150

Tel: (800) 711-6617

www.topinnovations.com

customerservice@topinnovations.com



Printed In China